

LWCF CLAMPING FORCE LOAD CELL (U.S. & METRIC)

FEATURES & BENEFITS

- Capacities from 15 to 1500 kN (3.37K to 337K lbf)
- Ideal for determining bolt preload
- Low height and robust design

LOADING DIAGRAM

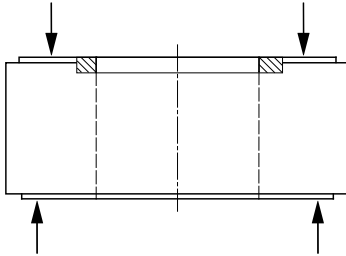

SPECIFICATIONS

ACCURACY - (MAX ERROR)		
Nonlinearity – %FS		±1
Nonrepeatability – %RO		±0.3
Creep, in 30 min – %		±1
TEMPERATURE		
Effect on Zero – %RO / deg	°C	±0.03
Effect on Output – % / deg	°C	±0.03
Compensated Range	°C	0 to +60
	°F	+32 to +140
Operating Range	°C	-30 to +80
	°F	-22 to +176
ELECTRICAL		
Output – mV/V ± %		1 ± 20
Excitation Voltage – VDC		2 - 6
Bridge Resistance – Ohm		250
MECHANICAL		
Safe Overload – %RO		150
Deflection at Rated Capacity	mm	< 0.1
	in	< 0.004
IP Rating		IP65
Material		Stainless steel

STANDARD CONFIGURATION

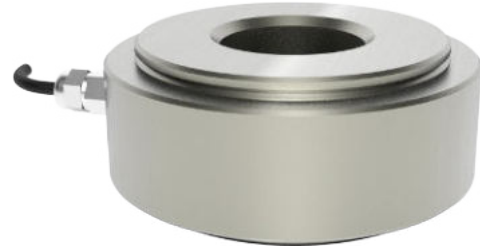

Model LWCF (Shown)

OPTIONS

- Special temperature range
- Internal shunt resistor – 100% output
- Standardized output
- Cable length
- Custom calibration
- Add connector to cable
- Transducer Electronic Data Sheet (TEDS)

CONNECTOR OPTIONS

- 3 m (9.8 ft) integral cable

ACCESSORIES

- Instrumentation

ELECTRICAL

Excitation (-)	Green
Excitation (+)	Brown
Signal (+)	Yellow
Signal (-)	White
Control signal (option)	Gray

LWCF CLAMPING FORCE LOAD CELL (U.S. & METRIC)

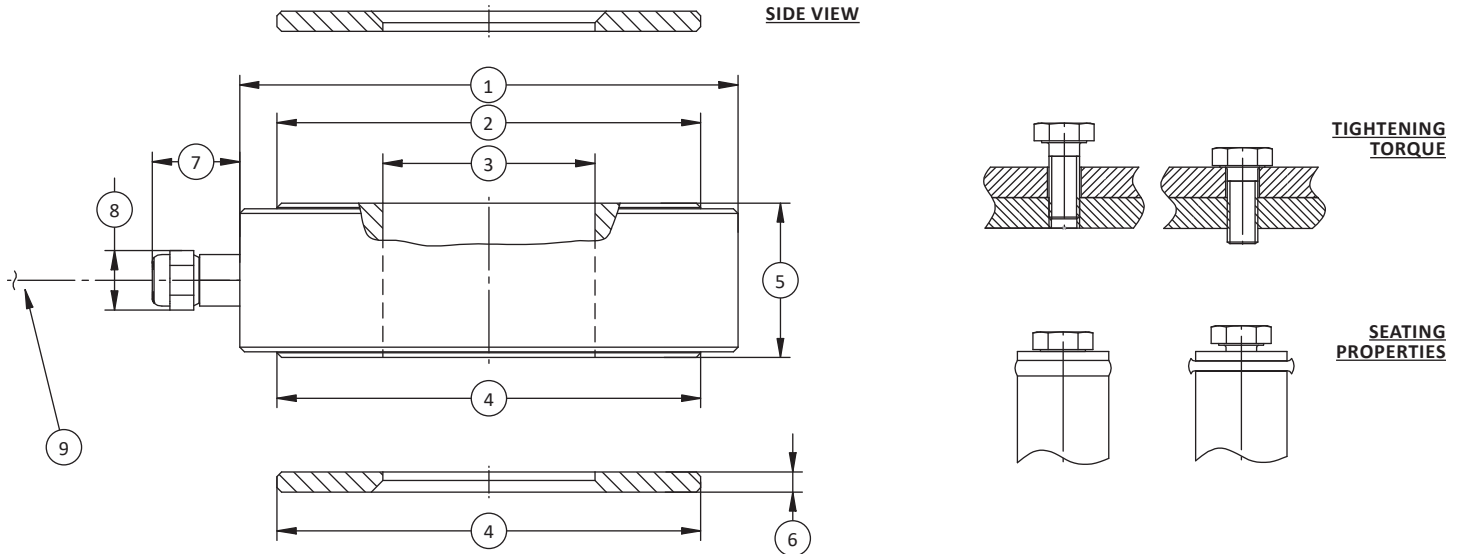

DIMENSIONS

See Drawing	CAPACITY													
	Metric (kN)	U.S. (lbf)	Metric (kN)	U.S. (lbf)	Metric (kN)	U.S. (lbf)	Metric (kN)	U.S. (lbf)	Metric (kN)	U.S. (lbf)	Metric (kN)	U.S. (lbf)	Metric (kN)	U.S. (lbf)
	mm	in	mm	in	mm	in	mm	in	mm	in	mm	in	mm	in
Screw	M6		M8		M10		M12		M16		M20		M24	
(1)	Ø24	Ø0.9	Ø27	Ø1.1	Ø33	Ø1.3	Ø37	Ø1.5	Ø44	Ø1.7	Ø50	Ø2.0	Ø65	Ø2.6
(2)	Ø12	Ø0.5	Ø16	Ø0.6	Ø22	Ø0.9	Ø26	Ø1.0	Ø33	Ø1.3	Ø39	Ø1.5	Ø54	Ø2.1
(3)	Ø6.3	Ø0.25	Ø8.3	Ø0.3	Ø10.3	Ø0.41	Ø12.3	Ø0.48	Ø16.3	Ø0.64	Ø20.3	Ø0.80	Ø24.5	Ø0.96
(4)	Ø12	Ø0.5	Ø16	Ø0.6	Ø22	Ø0.9	Ø26	Ø1.0	Ø33	Ø1.3	Ø39	Ø1.5	Ø54	Ø2.1
(5)	12	0.5	12	0.5	12	0.5	15	0.6	15	0.6	15	0.6	22	0.9
(6)	2	0.08	2	0.08	2	0.08	2.5	0.1	2.5	0.1	3	0.1	3	0.1
(7)	15	0.6	15	0.6	15	0.6	15	0.6	15	0.6	15	0.6	15	0.6
(8)	Ø10	Ø0.4	Ø10	Ø0.4	Ø10	Ø0.4	Ø10	Ø0.4	Ø10	Ø0.4	Ø10	Ø0.4	Ø10	Ø0.4
(9)	Ø3.2	Ø0.13	Ø3.2	Ø0.13	Ø3.2	Ø0.13	Ø3.2	Ø0.13	Ø3.2	Ø0.13	Ø3.2	Ø0.13	Ø3.2	Ø0.13

See Drawing	CAPACITY											
	Metric (kN)	U.S. (lbf)	Metric (kN)	U.S. (lbf)	Metric (kN)	U.S. (lbf)	Metric (kN)	U.S. (lbf)	Metric (kN)	U.S. (lbf)	Metric (kN)	U.S. (lbf)
	mm	in	mm	in	mm	in	mm	in	mm	in	mm	in
Screw	M30		M36		M39		M42		M48		M52	
(1)	Ø79	Ø3.1	Ø87	Ø3.4	Ø93	Ø3.7	Ø106	Ø4.2	Ø116	Ø4.6	Ø127	Ø5.0
(2)	Ø66	Ø2.6	Ø74	Ø2.9	Ø80	Ø3.1	Ø93	Ø3.7	Ø103	Ø4.1	Ø114	Ø4.5
(3)	Ø30.8	Ø1.2	Ø37	Ø1.5	Ø40	Ø1.6	Ø43	Ø1.7	Ø49	Ø1.9	Ø53.5	Ø2.1
(4)	Ø66	Ø2.6	Ø74	Ø2.9	Ø80	Ø3.1	Ø93	Ø3.7	Ø103	Ø4.1	Ø114	Ø4.5
(5)	27	1.1	27	1.1	27	1.1	30	1.2	30	1.2	35	1.4
(6)	3	0.1	3.5	0.1	4	0.2	4	0.2	4.5	0.2	4.5	0.2
(7)	15	0.6	15	0.6	15	0.6	15	0.6	15	0.6	15	0.6
(8)	Ø10	Ø0.4	Ø10	Ø0.4	Ø10	Ø0.4	Ø10	Ø0.4	Ø10	Ø0.4	Ø10	Ø0.4
(9)	Ø3.2	Ø0.13	Ø3.2	Ø0.13	Ø3.2	Ø0.13	Ø3.2	Ø0.13	Ø3.2	Ø0.13	Ø3.2	Ø0.13

LWCF v2.3 10-21-2022