

MODEL 313G CORROSION RESISTANT LEVEL TRANSMITTER



(Image shown with PTFE Cable)

STANDARD WIRING

WIRE	MODEL 313G
RED	+EXC/SIG
YEL	-EXC/SIG
BLU	GND
WHT	N/C
SHIELD	OPEN

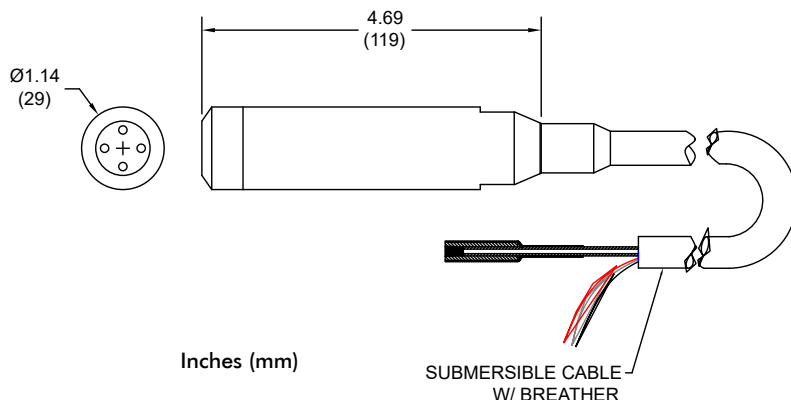

**REF DIMENSIONS ONLY.
CONSULT FACTORY FOR ACTUAL DIMENSIONS.**

PRODUCT OVERVIEW:

The Model 313G utilizes an all PVDF housing (titanium housing optional) with ceramic sensing element to provide a highly corrosion resistant level sensor. This series provides reliable performance in hazardous environments with aggressive chemicals for years of trouble free service.

FEATURES:

- Chemically resistant PVDF construction
- Bullet nose with ceramic sensing element
- 0 to 3 PSI thru 0 to 700 PSI (7 feet WC thru 1640 FTWC)
- PTFE jacketed vented cable
- IP68 rating to 700 PSI (1640 FT)

APPLICATIONS:

- Corrosive chemical tank level
- Water tank and reservoir level
- Process plant water level
- Ground water reclamation

OPTIONS:

- Additional lengths of Teflon jacketed cable
- 0-5Vdc output

GP:50 MODEL 313G

REFERENCE SPECIFICATIONS

(Standard configurations shown, consult factory for other options)

ELECTRICAL	
Output Signal:	Model 313G: 4-20 mA Model 213G: 0-5 Vdc
Excitation Voltage:	12 to 36 Vdc
Response Time:	<5 ms

MATERIALS OF CONSTRUCTION	
Housing:	PVDF, Titanium optional
Sensor Diaphragm:	Ceramic (other options available, consult factory)
O-Ring Seal:	FKM Fluorocarbon rubber

ACCURACY (BFSL): Hysteresis, non-Linearity & Repeatability @ + 70 °F	
Standard:	±0.5% FSO
Improved:	±0.25% FSO

MECHANICAL	
Electrical Connection:	Teflon jacketed cable with integrated vent tube and hydrophobic filter
Proof Pressure:	2X FSO
Burst Pressure:	3X FSO
Weight:	>1.0 lbs (680 g)
Diameter:	1.14" (29 mm)

PRESSURE RANGES	
0 to 3 PSI thru 0 to 700 PSI (207 mBAR thru 48 BAR)	
0 to 6.5 FTWC thru 0 to 1640 FTWC (2 mWC thru 500 mWC)	

THERMAL SPECIFICATIONS	
Operating Range:	-40 °F to +185 °F (-40 °C to +85 °C)
Compensated Range:	15 °F to +168 °F (-10 °C to +76 °C)
Storage:	-40 °F to +212 °F (-40 °C to +100 °C)
Effect on Zero/Span:	<±1.4% FSO/100 °F

GP:50

WASTE WATER SUBMERSIBLES

