

MODEL 375

API FLANGED PRESSURE TRANSMITTER

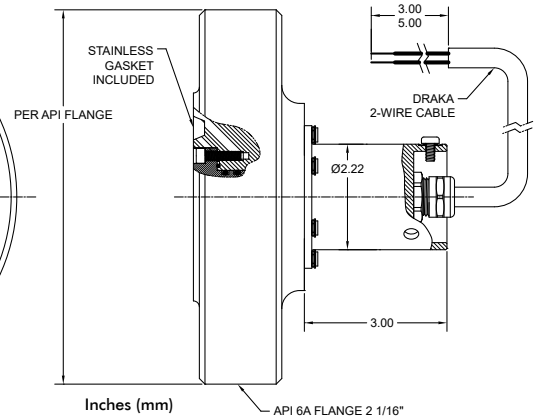
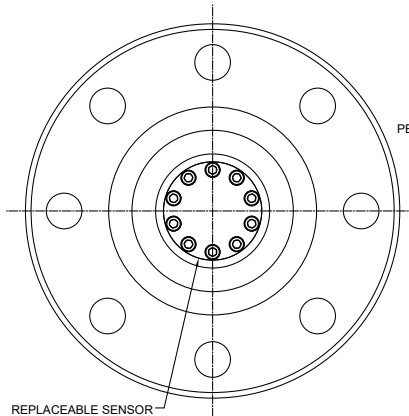

**REF DIMENSIONS ONLY.
CONSULT FACTORY FOR ACTUAL DIMENSIONS.**

PRODUCT OVERVIEW:

The Model 375 Series from GP:50 is an API flanged pressure transmitter, offering over 10 years of field-proven pedigree. This Series features a robust design with all stainless steel housing and optional Inconel wetted parts. The compact design provides a highly reliable and accurate transmitter that provides years of trouble-free use. There is an optional redundant sensor design that provides backup in case of primary sensor failures. Optional HART communication protocol is available for field adjustment options.

FEATURES:

- API flanged process connections up to 4-1/16"
- Pressure and temperature output option
- Inconel wetted parts
- Ranges from 0-3,000 thru 0-30,000 PSI
- Optional HART communication protocol
- Offshore ratings

APPLICATIONS:

- BOP controls
- Wellhead & riser controls
- Lubricator systems
- Offshore oil platforms

OPTIONS:

- Redundant sensors and outputs
- Inconel or Hastelloy wetted material
- Subsea rated electrical connectors
- API rated flanges from 2-1/16" to 4-1/16"
- HART communication protocol
- ATEX/IEC Intrinsically Safe, Zone 2, Flameproof*

*For details of available approvals go to:
<https://www.gp50.com/certifications>

GP:50 MODEL 375

REFERENCE SPECIFICATIONS

(Standard configurations shown, consult factory for other options)

ELECTRICAL	
Output Signal:	4-20 mA both pressure and temperature HART optional
Excitation Voltage:	12 to 36 Vdc 18 to 36 Vdc for HART communication (250 Ω load required)

MATERIALS OF CONSTRUCTION	
Wetted Parts:	718 Inconel & 4130 SS (Optional Inconel or Hastelloy inlay)
Housing:	316 Stainless Steel

ACCURACY (RSS): Hysteresis, Non-Linearity & Repeatability @ +70 °F)	
Standard:	±0.2% FSO
Improved:	±0.1% FSO
Zero Balance:	±0.5% FSO pressure and temperature
Span:	±0.5% FSO pressure and temperature
Stability:	±0.5% FSO/year

MECHANICAL	
Electrical Connection:	MSSL-12-FCR-PBOF
Proof Pressure:	1.5X pressure range
Burst Pressure:	2.5X FSO pressure range
API Flange:	2-1/16" thru 4-1/16" Flush or extended nose versions
Approximate Weight:	180 lbs

PRESSURE RANGES	
0 to 5K thru 0 to 25K PSI (345 thru 1,724 BAR)	

THERMAL SPECIFICATIONS	
Operating Range:	Electronics: +15 °F to +185 °F (-10 °C to +85 °C) HART: +15 °F to +160 °F (-10 °C to +70 °C)
Compensated Range:	+32 °F to +392 °F (0 °C up to +200 °C)
Process:	+15 °F to +392 °F (-10 °C to +200 °C)
Effect on Zero/Span:	±0.5% FSO per CTR
Optional Variations:	Consult factory

APPROVALS	
ATEX/IEC Intrinsically Safe: Zone 2, Flameproof	

