

## Miniaturized pressure sensor

3.80 mm up to 180C°

MMP-004-3.80-XXX-S-YYYY-A-ZZ

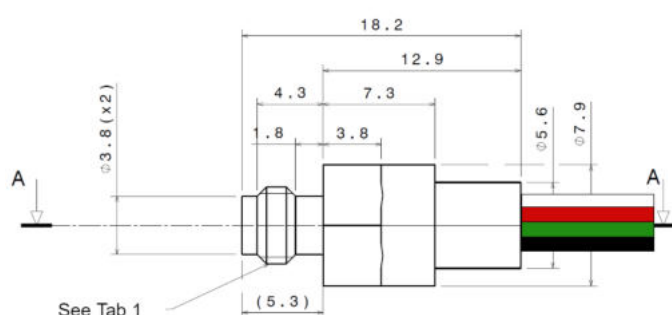
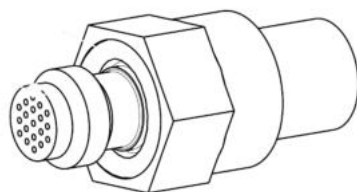

See Tab 1

Tab 1	
Type	Value
Metric	M5x0.5
Imperial	10-32 UNF-2A

### MODEL DEFINITION

**XXX: SST:** mechanical casing in stainless steel

**S:** M for metric, I for Imperial

**YYYY:** pressure range in PSI (0005,0030,0100, 0300)

**A:** absolute pressure measurement

**ZZ:** **ST:** standard temperature up to 100C°

**HT:** high temperature up to 185C°

**Options:** special tube length, material and grid shape also available on request

### OVERVIEW

- Outer diameter 3.80 mm
- From 0.35 to 20 Bar Absolute pressure sensor
- Wide temperature range up to 185C°
- Harsh environment
- Customized solution possible
- mVolt output
- Highest resonance frequency on the market
- Amplification can be done for a special request

### APPLICATIONS

- Instrumentation (ie: Automotive, ...)
- Aerodynamic testing (ie: wind tunnel)
- Industrial process monitoring
- Pumps
- Biomedical
- Oil and gas
- ...

PART NUMBER

MMP-3.80-004-XXX-S-YYYY-A-ZZ

Pressure Range	Burst Pressure
0 → 5 PSI	15 PSI
0 → 30 PSI	90 PSI
0 → 100 PSI	300 PSI
0 → 300 PSI	900 PSI

Characteristic		Minimum	Typical	Maximum	Unit
Span <sup>4@</sup> 5V	0 → 5 PSI	75	100	125	mV
	0 → 30 PSI	75	100	125	
	0 → 100 PSI	75	100	125	
	0 → 300 PSI	75	100	125	
Zero Offset <sup>1</sup>		-10	0	10	mV/V
Bridge Resistance (RB)		4	5	6	kΩ
Non-linearity <sup>1</sup>		-0.2	0	0.2	% FS
Pressure hysteresis <sup>1</sup>		-0.1	0	0.1	% FS
Operating Temperature <sup>2</sup>		-	-	+185	°C
Max Excitation Voltage		-	5	10	V
TC Sensitivity <sup>3</sup>		-1400	-1900	-2400	PPM/°C
TC Zero Offset <sup>3</sup>		-30	0	30	μV/V/°C
TC Resistance <sup>3</sup>		2000	2500	3000	PPM/°C
Thermal hysteresis <sup>1</sup>		-0.2	0	0.2	% FS

#### Remark:

- All sensors are provided with a control sheet given pressure level versus mVolt @25C° under a supply voltage of 5 Volt.
- Temperature measurement/compensation available. [See our tutorial on our website.](#)
- Conditioning system on request.
- High robustness: specific protection on wire bonding @MEMS level (protection against particles, dust, condensation... ) without impact on frequency measuring range.

1 | Accuracy @25 Celsius ; 2 | TMCL qualification tests – JEDEC JESD22-A104 « temperature cycling » @ Tmax ; 3 | @MEMS level; 4 | Amplification can be done for a special request

## CONTACT

**Operational Headquarter:** Rue des Ormes 151, B-4800 Lambermont, BELGIUM

**TEL:** +32 87 70 96 69

**Email:** sales@sensorade.be