



Power-over-Ethernet Adapter for TE NetScanner Range

- **Enables the TE NetScanner range to be used with the convenience of PoE**
- **Compatible with all NetScanner range - 9116, 9216, 9022, 9046, 9146, 9146-R, 9032, 9033, 9034, 9038 and Initium products.**
- **Features M12 connector so off-the-shelf cabling can be used.**
- **Conforms to IEEE 802.3at**
- **Compatible with IEEE 1588 PTPv2 enabled devices.**
- **Available with optional support brackets for 9216.**



The Chell Power Over Ethernet (PoE) adapter can be fitted onto any of the TE NetScanner range and brings the convenience of PoE to these products.

The PoE 9000 simply connects to the NetScanner device using the circular multi-way connector. The PoE enabled Ethernet connection is then made via the M12 connector on the top of the product.

On connection, the PoE9000 will negotiate with the network switch and power will be supplied to the NetScanner product. From an Ethernet point of view, the PoE9000 is transparent and communications with the NetScanner product will be unaffected.

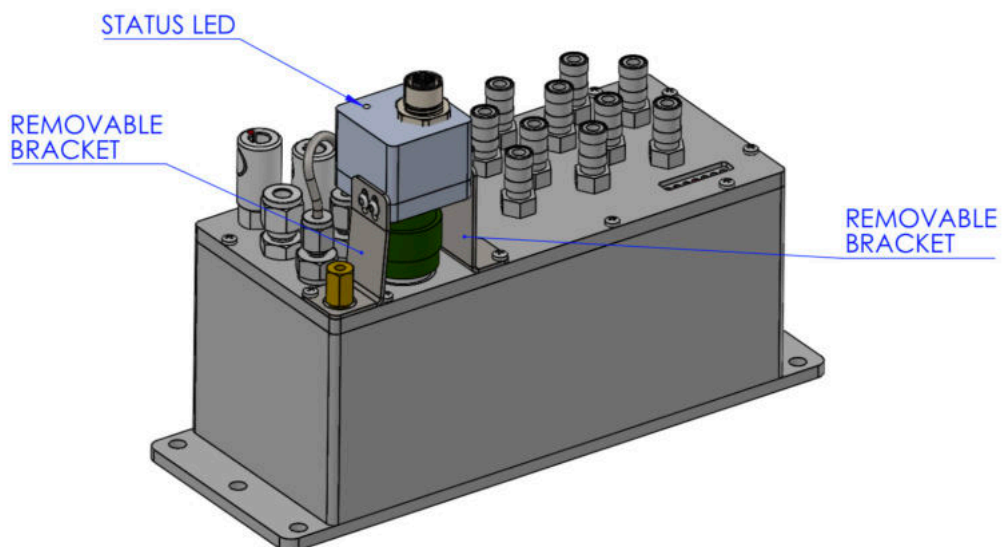

FlightDaq-TL System Specifications		
Dimensions	77 x 37 x 37mm	
Environmental sealing	IP67	
Input supply	PoE	IEEE 802.3at
Electrical connector	M12 X-Coded TE2232331-1	
Operating temperature range.	-20 to+90°C (lower range can be extended if unit is powered first)	
Maximum relative humidity	95% at 50°C (non-condensing)	

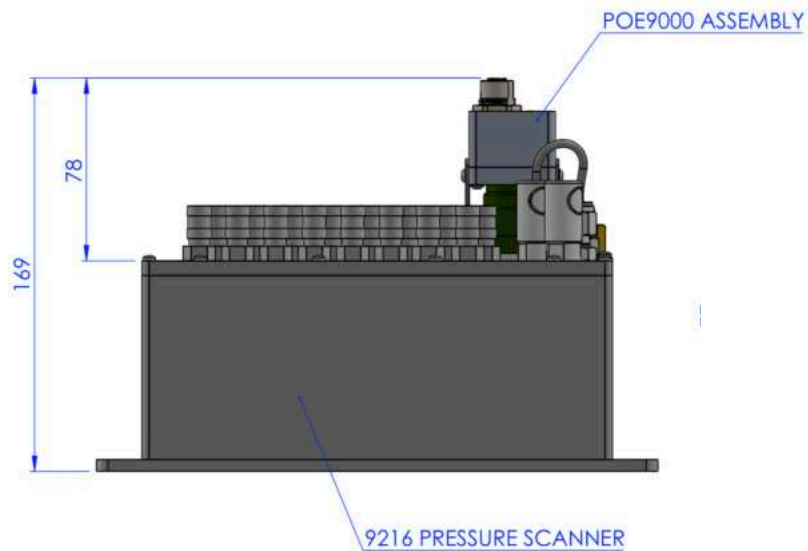
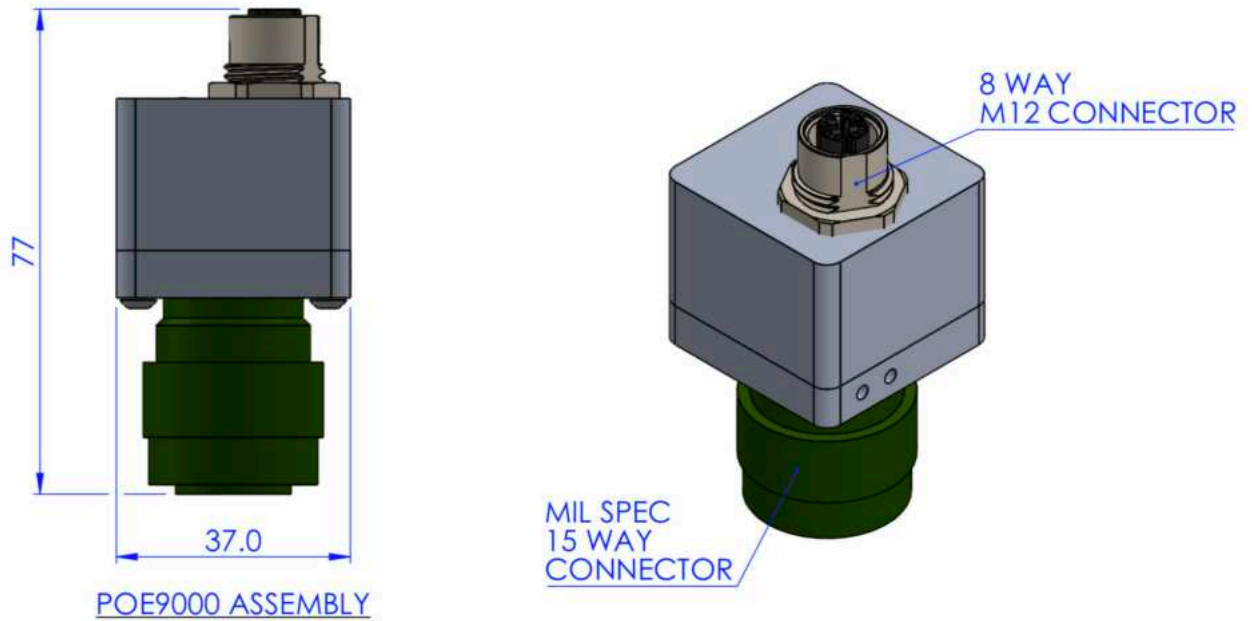

Chell Instruments Ltd
 Folgate House
 Folgate Road
 North Walsham
 Norfolk NR28 0AJ
 England



Tel.: +44 (0)1692 500555
 Fax: +44 (0)1692 500088

E-mail : sales@chell.co.uk

