

5330 HOLLOW FLANGE REACTION TORQUE TRANSDUCER (U.S. & METRIC)

FEATURES & BENEFITS

- High torsional stiffness
- Extraneous load resistance
- Compact size
- Large thru-hole

SPECIFICATIONS

ACCURACY – (MAX ERROR)		
Nonlinearity – %FS		±0.1
Hysteresis – %FS		±0.25
Nonrepeatability – %RO		±0.05
TEMPERATURE		
Effect on Output – % / deg	°F	±0.002
Effect on Zero – %RO / deg	°F	±0.002
Compensated Range	°F	+75 to +175
	°C	+24 to +80
Operating Range	°F	-65 to +225
	°C	-54 to +107
ELECTRICAL		
Rated Output – mV/V (Nominal)	60, 120 lbf-in 6.78, 13.6 Nm	1.25
	240 lbf-in 27.1 Nm	1.5
	600, 1.2K lbf-in 67.8, 136 Nm	1.25
	3K, 6K lbf-in 339, 679 Nm	1.0
	10K, 20K, 50K, 100K lbf-in 1.13K, 2.26K, 5.56K, 11.3K Nm	2.0
	Bridge Resistance – Ohm (Nominal)	60 - 1.2K lbf-in 6.78 - 136 Nm
3K - 100K lbf-in 339 - 11.3K Nm		700
Excitation Voltage – VDC MAX		10
MECHANICAL		
Calibration		CW & CCW
Safe Overload – %CAP		200
Material	60 - 120 lbf-in 6.78 - 13.6 Nm	Aluminum
	240 - 100K lbf-in 27.1 - 11.3K Nm	4340 Nickel Plated Stainless steel

STANDARD CONFIGURATION



MODEL 5330 (Shown)

PERFORMANCE PARAMETERS

CAPACITY		MAX THRUST LOAD		MAX BENDING MOMENT	
lbf-in	Nm	lbf	N	lbf-in	Nm
60	6.78	100	445	50	5.65
120	13.6	120	534	60	6.78
240	27.1	240	1.07K	120	13.6
600	67.8	600	2.67K	300	33.9
1.2K	136	1.2K	5.34K	600	67.8
3K	339	3K	13.3K	1.5K	169
6K	678	6K	26.7K	3K	339
10K	1.13K	2.5K	11.1K	2.25K	254
20K	2.26K	5K	22.2K	4.5K	508
50K	5.65K	10K	44.5K	10K	1.13K
100K	11.3K	20K	89K	20K	2.26K

Datasheet 5330 Hollow Flange v1.4 11-1-2017

U.S. dimensions and capacities are provided for conversion only. Standard products have International System of Units (SI) capacities and dimensions.

5330 HOLLOW FLANGE REACTION TORQUE TRANSDUCER (U.S. & METRIC)

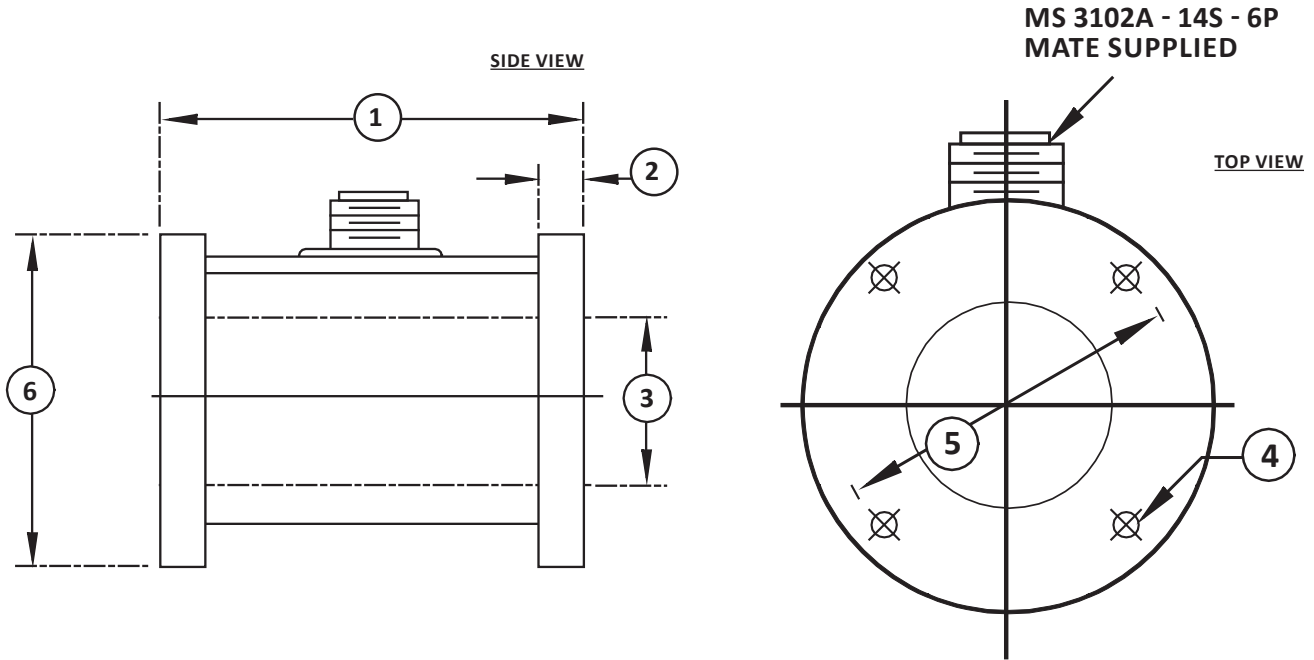

DIMENSIONS

See Drawing	CAPACITY									
	U.S. (lbf-in)	Metric (Nm)	U.S. (lbf-in)	Metric (Nm)	U.S. (lbf-in)	Metric (Nm)	U.S. (lbf-in)	Metric (Nm)	U.S. (lbf-in)	Metric (Nm)
	in	mm	in	mm	in	mm	in	mm	in	mm
	60, 120, 240	6.78, 13.6, 17.1	600, 1200	67.8, 136	3K, 6K	339, 678	10K, 20K	1.13K, 2.26K	50K, 100K	5.65K, 11.3K
(1)	2.125	53.98	2.125	53.98	2.125	53.98	3.5	88.9	3.5	88.9
(2)	0.3125	7.938	0.3125	7.938	0.3125	7.938	0.625	15.88	0.625	15.88
(3)	0.875 THRU	22.23 THRU	1.375 THRU	34.93 THRU	2.375 THRU	60.33 THRU	3.375 THRU	85.73 THRU	3.375 THRU	85.73 THRU
(4)	0.203 THRU 2 places	5.16 THRU 2 places	0.39 THRU 2 places	9.9 THRU 2 places	0.406 THRU 4 places	10.31 THRU 4 places	3/8 - 24 UNF 6 places		0.63 THRU 8 places	16.0 THRU 8 places
(5)	2.0	50.8	2.5	63.5	3.375	85.73	4.375	111.13	7.00	177.8
(6)	2.5	63.5	3.25	82.6	4.0	101.6	5.0	127.0	8.5	215.9

Notes:
 - Error due to bending <1% FS at maximum allowable bending load.
 - Allowable loads cannot be applied simultaneously