

## T6 DUAL RANGE ROTARY TORQUE TRANSDUCER (U.S. & METRIC)

### FEATURES & BENEFITS

- Dual range capacities – 10:1 ratio (5/0.5 to 20K/2K Nm) (44.3/4.43 to 177K to 17.7K lbf-in)
- ±5 VDC output
- Digital electronics
- Stainless steel shaft
- 12 to 28 VDC supply
- Contactless
- 5 kHz sample rate – each range
- 16-bit

### SPECIFICATIONS

ACCURACY – (MAX ERROR)		
Combined Error – %FS		±0.1
Nonrepeatability – %FS		±0.02
TEMPERATURE		
Effect on Zero – % RO / deg	°C	±0.02
Effect on Output – % / deg	°C	±0.01
Rated Range	°C	+5 to +45
	°F	+41 to +113
Operating Range	°C	0 to +60
	°F	+32 to +140
ELECTRICAL		
Output – VDC		±5
Bandwidth – kHz – dB		3 – 3
Calibration Signal – %RO		100
Speed Output – puls/rev.		60
Supply Voltage – VDC		+12 to +28
Supply Current – mA		60
Electrical Connection – pin		12
Resolution – bit		16
Sample Rate – kHz		5
MECHANICAL		
Safe Overload – %RO		200
Max Speed – RPM		Varies with capacity (see table)
Shaft Material		Stainless steel
Housing Material		Aluminum

U.S. dimensions and capacities are provided for conversion only. Standard products have International System of Units (SI) capacities and dimensions.

### STANDARD CONFIGURATION



MODEL T6 (Shown)

### OPTIONS

- Speed & angle measurement – 360 pulse TTL, 2-tracks 90° offset, available on capacities up to 1K Nm (8.85K lbf-in) only
- Speed output - 60 Pulse TTL, 1-track, available on capacities 2K Nm (17K lbf-in) & above
- +10V torque output
- RS485
- Keyed shafts - per Din 6885.1

## T6 DUAL RANGE ROTARY TORQUE TRANSDUCER (U.S. & METRIC)

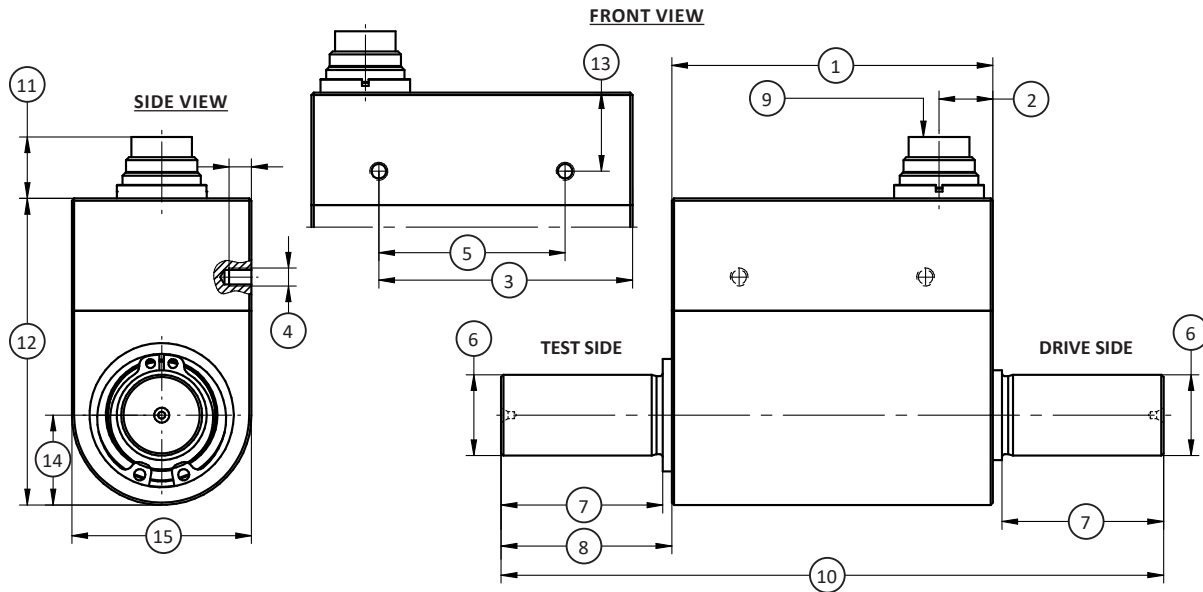

### DIMENSIONS

See Drawing	CAPACITIES									
	Metric (Nm)	U.S. (lbf-in)	Metric (Nm)	U.S. (lbf-in)	Metric (Nm)	U.S. (lbf-in)	Metric (Nm)	U.S. (lbf-in)	Metric (Nm)	U.S. (lbf-in)
	5/0.5	44.3/4.43	10/1	88.5/8.85	20/2, 30/3	177/17.7, 265/26.5	50/5, 100/10	443/44.3, 885/88.5	200/20, 300/30, 500/50	1.77K/177, 2.7K/267, 4.43K/443
	mm	in	mm	in	mm	in	mm	in	mm	in
(1)	71.5	2.81	71.5	2.81	71.5	2.81	71.5	2.81	80.5	3.17
(2)	12	0.5	12	0.5	12	0.5	12	0.5	12	0.5
(3)	56.5	2.22	56.5	2.22	56.5	2.22	56.5	2.22	55.5	2.12
(4)	2 x M4		2 x M4		2 x M4		2 x M4		2 x M4	
(5)	41.5	1.63	41.5	1.63	41.5	1.63	41.5	1.63	29.5	1.16
(6)	∅8g6	∅(0.3156 / 0.3150)	∅10g6	∅(0.3943 / 0.3937)	∅18g6	∅(0.7094 / 0.7087)	∅18g6	∅(0.7094 / 0.7087)	∅32g6	∅(1.2608 / 1.2598)
(7)	17	0.7	17	0.7	18	0.7	36	1.4	38	1.5
(8)	18	0.7	18	0.7	20	0.8	38	1.5	39.5	1.6
(9)	Connector 12-pin		Connector 12-pin		Connector 12-pin		Connector 12-pin		Connector 12-pin	
(10)	107.5	4.23	107.5	4.23	111.5	4.39	147.5	5.81	159.5	6.28
(11)	14	0.5	14	0.5	14	0.5	14	0.5	14	0.5
(12)	68.2	2.69	68.2	2.69	68.2	2.69	68.2	2.69	86.2	3.39
(13)	17.5	0.69	17.5	0.69	17.5	0.69	17.5	0.69	17	0.7
(14)	20	0.8	20	0.8	20	0.8	20	0.8	30.5	1.20
(15)	40	1.6	40	1.6	40	1.6	40	1.6	61	2.4

\*5/0.1 Nm capacity has 8 mm g6 shaft and 110/11 Nm capacity has 10 mm g6 shaft

## T6 DUAL RANGE ROTARY TORQUE TRANSDUCER (U.S. & METRIC)

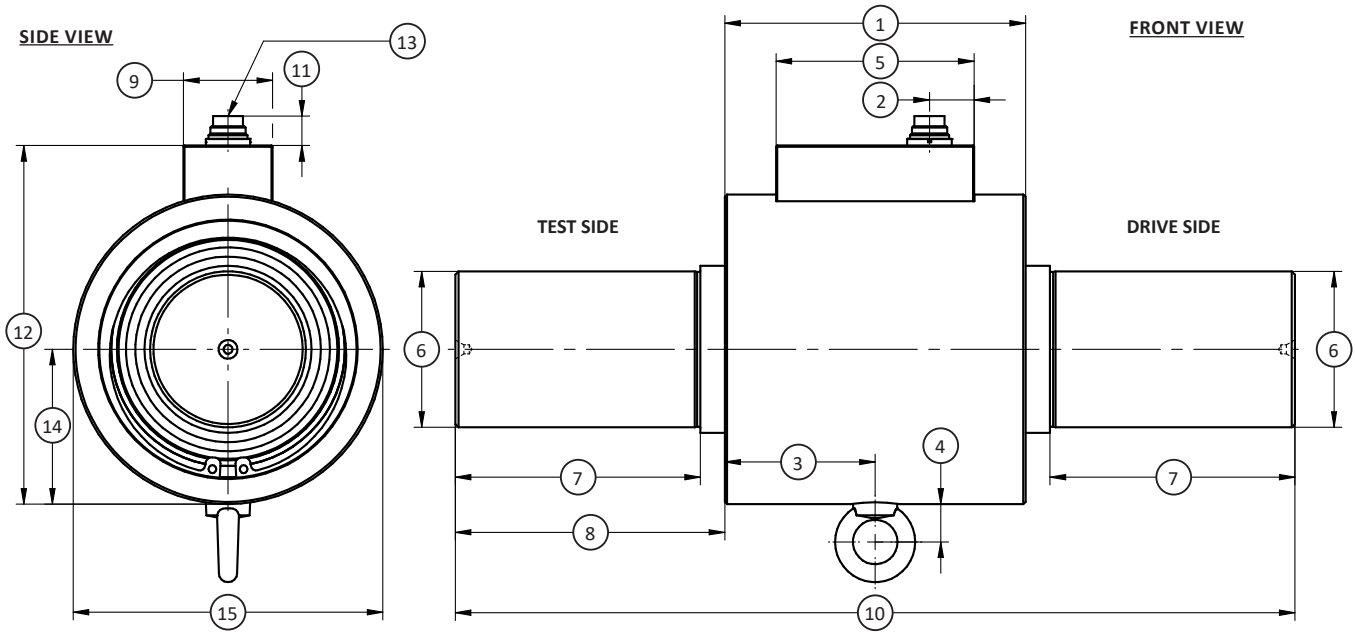

### DIMENSIONS (CONTINUED)

See Drawing	CAPACITIES					
	Metric (Nm)	U.S. (lbf-in)	Metric (Nm)	U.S. (lbf-in)	Metric (Nm)	U.S. (lbf-in)
	1K/100	8.85K/885	2K/200, 5K/500	17.7K/1.77K, 44.3K/4.43K	10K/1K, 20K/2K	88.5K/8.85K, 177K/17K
	mm	in	mm	in	mm	in
(1)	130	5.12	135	5.31	190	7.48
(2)	20	0.8	20	0.8	20	0.8
(3)	64.5	2.54	67.5	2.66	95	3.7
(4)	17	0.7	17	0.7	17	0.7
(5)	89	3.5	89	3.5	89	3.5
(6)	Ø50 g6 TYP	Ø(1.9695 / 1.9685) TYP	Ø70 g6 TYP	Ø(2.7571 / 2.7559) TYP	Ø110 g6 TYP	Ø(4.3321 / 4.3307) TYP
(7)	58 TYP	2.28 TYP	110 TYP	4.33 TYP	120 TYP	4.72 TYP
(8)	66 TYP	2.60 TYP	121 TYP	4.76 TYP	140 TYP	5.51 TYP
(9)	40	1.6	40	1.6	40	1.6
(10)	262	10.31	377	14.84	470	18.50
(11)	13	0.5	13	0.5	13	0.5
(12)	136	5.35	161	6.34	233	9.17
(13)	Connector 12-pin		Connector 12-pin		Connector 12-pin	
(14)	57.5	2.26	69.5	2.74	105	4.09
(15)	115	4.53	139	5.47	210	8.27

## T6 DUAL RANGE ROTARY TORQUE TRANSDUCER (U.S. & METRIC)

### PERFORMANCE PARAMETERS

CAPACITY		MAX RPM	SPRING RATE	MOMENT OF INERTIA (Kg•m <sup>2</sup> )		MAX THRUST LOAD		MAX SHEAR FORCE	
Nm	lbf-in		(NM/rad)	Drive Side	Test Side	N	lbf	N	lbf
5/0.5	44.3/4.43	15,000	2.1x10 <sup>2</sup>	9.0x10 <sup>-6</sup>	8.4x10 <sup>-6</sup>	450	101	3	0.67
10/1	88.5/8.85	15,000	7.1x10 <sup>2</sup>	9.3x10 <sup>-6</sup>	8.5x10 <sup>-6</sup>	710	160	12	2.70
20/2	177/17.7	15,000	1.9x10 <sup>3</sup>	1.1x10 <sup>-5</sup>	9.9x10 <sup>-6</sup>	1.15K	259	23	5.17
30/3	266/26.6	15,000	2.9x10 <sup>3</sup>	1.1x10 <sup>-5</sup>	9.9x10 <sup>-6</sup>	1.5K	337	35	7.87
50/5	443/44.3	15,000	5.4x10 <sup>3</sup>	1.3x10 <sup>-5</sup>	1.1x10 <sup>-5</sup>	2.15K	483	45	10.1
100/10	885/88.5	12,000	8.0x10 <sup>3</sup>	1.3x10 <sup>-5</sup>	1.2x10 <sup>-5</sup>	3.4K	764	90	20.3
200/20	1.77K/177	12,000	3.4x10 <sup>4</sup>	1.1x10 <sup>-4</sup>	8.4x10 <sup>-5</sup>	5.8K	1.3K	175	39.3
500/50	4.43K/443	10,000	6.3x10 <sup>4</sup>	1.2x10 <sup>-4</sup>	8.6x10 <sup>-5</sup>	10K	2.25K	410	92.2
1K/100	8.85/885	8,000	2.0x10 <sup>5</sup>	1.6x10 <sup>-3</sup>	1.1x10 <sup>-3</sup>	16.2K	3.65K	530	119
2K/200	17.7K/1.77K	5,500	5.1x10 <sup>5</sup>	5.3x10 <sup>-3</sup>	4.2x10 <sup>-3</sup>	25K	5.62K	720	162
5K/500	44.3K/4.43K	5,500	7.2x10 <sup>5</sup>	5.3x10 <sup>-3</sup>	4.3x10 <sup>-3</sup>	42K	9.44K	1850	416
10K/1K	88.5K/8.85	5,000	3.1x10 <sup>6</sup>	4.1x10 <sup>-2</sup>	3.6x10 <sup>-2</sup>	66K	14.8K	2700	607
20K/2K	177K/17.7K	5,000	3.7x10 <sup>6</sup>	4.1x10 <sup>-2</sup>	3.7x10 <sup>-2</sup>	98K	22K	5200	1.17K

### ELECTRICAL CONNECTION

Pin	12-PIN ELECTRICAL CONNECTION	
	Function	Description
A	NC	–
B	Option Angle B	TTL
C	Signal (+)	±5 (±10) VDC
D	Signal (GND)	0 VDC
E	Supply (GND)	0 VDC
F	Supply (+)	12-28 V
G	Option Angle A	TTL
H	Signal 2 (+)	±5 (±10) VDC
J	NC	–
K	Cal. Control	L < 2.0V / H > 3.5V
L	NC	–
M	Shield	Transducer Housing